

**125CC/150CC**

**OWNERS' MANUAL**

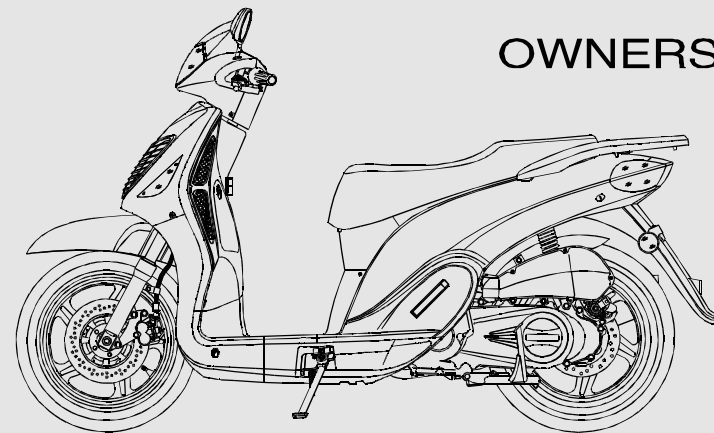

## **TO OWNERS**

Thank you for selecting the scooter. For safer and pleasant driving, a complete understanding for all the instructions in this manual is required. A safer and pleasant driving depends on your driving skill, your understanding of all operations as well as your knowledge of the mechanic performance of the scooter. Making inspections before driving and performing periodical maintenance are basic requirements.

For periodic maintenance or repair, please consult our local dealer. They will help you optimize the performance of your scooter.

Wish you a pleasant drive.

The manufacturer reserve the right to make improvement of the product at any time without prior notice and without any obligation whatever.

# **IMPORTANT SAFETY INFORMATION**

## **DRIVER AND PASSENGER**

150T-5/150T-5A/125T-21/125T-21 A is designed only for one driver and one passenger ; the total load must not exceed the limit specified in the manual.

## **ROAD CONDITION**

The scooter is designed only for driving on highways.

## **READ THIS MANUAL CAREFULLY**

Pay special attention to all the sentences or paragraphs marked with WARNING in this manual.

## **WARNING:**

Failure to follow WARNING could result in severe injury or death.

## **CAUTION:**

A CAUTION indicates that special precautions must be taken to follow the instructions in the manual & avoid body injury or damage to the scooter.

## **NOTE:** A Note provides the information for effective operation.

This manual should be taken as a permanent part of the scooter. In case you want to transfer the scooter, make sure the manual is also transferred to the new owner.

# CONTENTS

Traffic safety.....	1	Parking.....	22
Important information for safe driving.....	2	Maintenance interval.....	23
Loading.....	3	Maintenance interval table.....	25
Parts and control.....	4	Maintenance.....	26
Operation guide.....	7	Air cleaner.....	26
Main switch.....	7	Small air cleaner.....	26
Temperature indicator.....	8	Left side cover inlet ventilator.....	27
Fuel level indicator.....	9	Radiator.....	28
Baggage hook.....	9	Engine oil.....	28
Handle bar Switch (L).....	10	Replacing engine oil and cleaning oil screen.....	29
Handle bar Switch (R).....	11	Replacing gearbox oil.....	30
Front trunk.....	12	Spark plug.....	31
Steering lock.....	12	Battery.....	31
Seat lock.....	13	Replacing the fuse.....	32
Trunk.....	13	Tools.....	33
Inspection before driving.....	14	Serial number.....	34
Starting the engine.....	19	Guideline for storage.....	35
Driving.....	20	Technical parameter.....	37
Driving procedure.....	20	Electrical Diagram.....	39
Braking the scooter.....	21		

# **TRAFFIC SAFETY**

## **SAFETY CAN BE ENSURED ONLY BY DRIVER HIMSELF.**

### **NOTES:**

A driver will always spend much time learning driving skills in areas with less traffic before he could drive on the highway.

1.Many scooter accidents occur due to that automobile driver cannot see the scooter driver. Therefore, the scooter driver should keep himself clear in the sight of the automobile driver.

For example:

- Wear colourful clothing;
- Avoid careless driving.

2.Many accidents occur at the crossroad, entrance or exit of parking lot and driveway. Therefore precautions must be taken in these places;

3.Over speeding is one of the main causes for many scooter accidents. Please obey the traffic rules and drive within the speed limit;

4.Many scooter accidents occur due to insufficient experience. A new driver should understand the performance of scooter before riding on the highway. Never lend scooter to inexperienced drivers;

5.Most injuries of scooter accidents are on head. Therefore please wear helmet and other protections, e.g. goggles, boots and thick coat.

6.Do not ride on the expressways. Be specially careful if you have to drive on expressways;

7.Do not drive on bump road, or you may loose control or damage the scooter.

## **IMPORTANT INFORMATION FOR SAFE DRIVING**

1. Before driving, please carefully inspect the scooter. (Refer to Page 14);
2. For safety, please wear helmet as well as boots, gloves, goggles and colourful clothing;
3. The rear box or cargo box installed by user himself is for light things only. If installing cargo boxes on two sides of scooters, please load equally on both and hold tightly in order not to move around when driving. For details, refer to page 3;
4. When driving, please hold the steering handlebar with both hands & rest your feet on the foot-rest deck.
5. Turn on the wipers before turning or changing lane.

# LOADING

## WARNING:

Trunk or storage equipment etc., are for light loads only.

Load limit:

Trunk	10kg
Rear bracket	5kg

- Max. Load capacity: 150kg;
- Overload will affect the stability and controllability;
- All the loads should be hold firmly;
- Do not carry children or pets on the bracket or in the trunk, e.g cats & dogs;
- All the loads should be well kept in the trunk.

# PARTS AND CONTROLS

## THE ASSEMBLING POSITIONS OF CONTROLS

- ① Rear brake lever
- ② Instruments ASSY
- ③ Front left trunk
- ④ Battery
- ⑤ Trunk
- ⑥ Air cleaner
- ⑦ Footrest deck
- ⑧ Side stand
- ⑨ Main stand
- ⑩ Frame number (VIN )

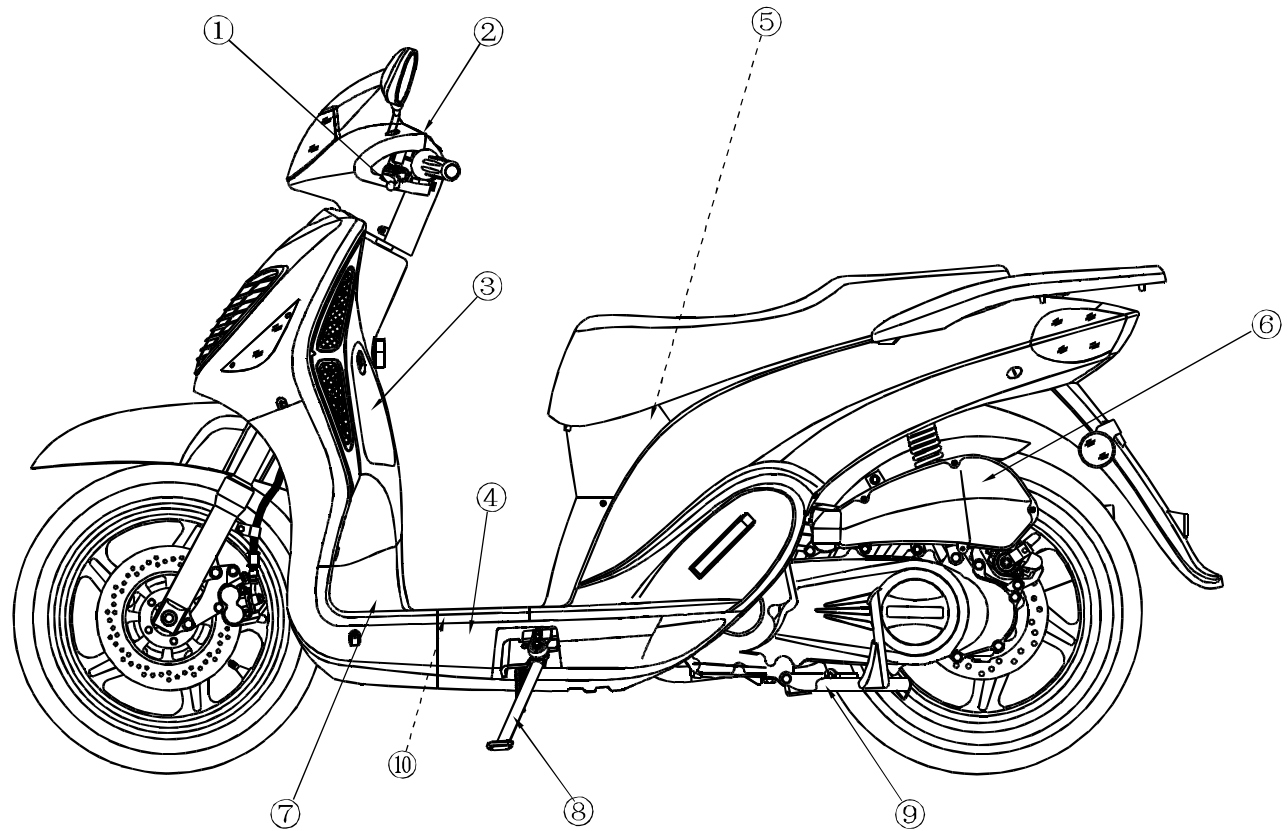

The position marked with ----- indicate the parts you may not see.



- ① Fuel tank
- ② Ignition switch lock
- ③ Front right trunk
- ④ Front brake lever
- ⑤ Secondary water tank
- ⑥ Muffler
- ⑦ Water inlet
- ⑧ Frame plate

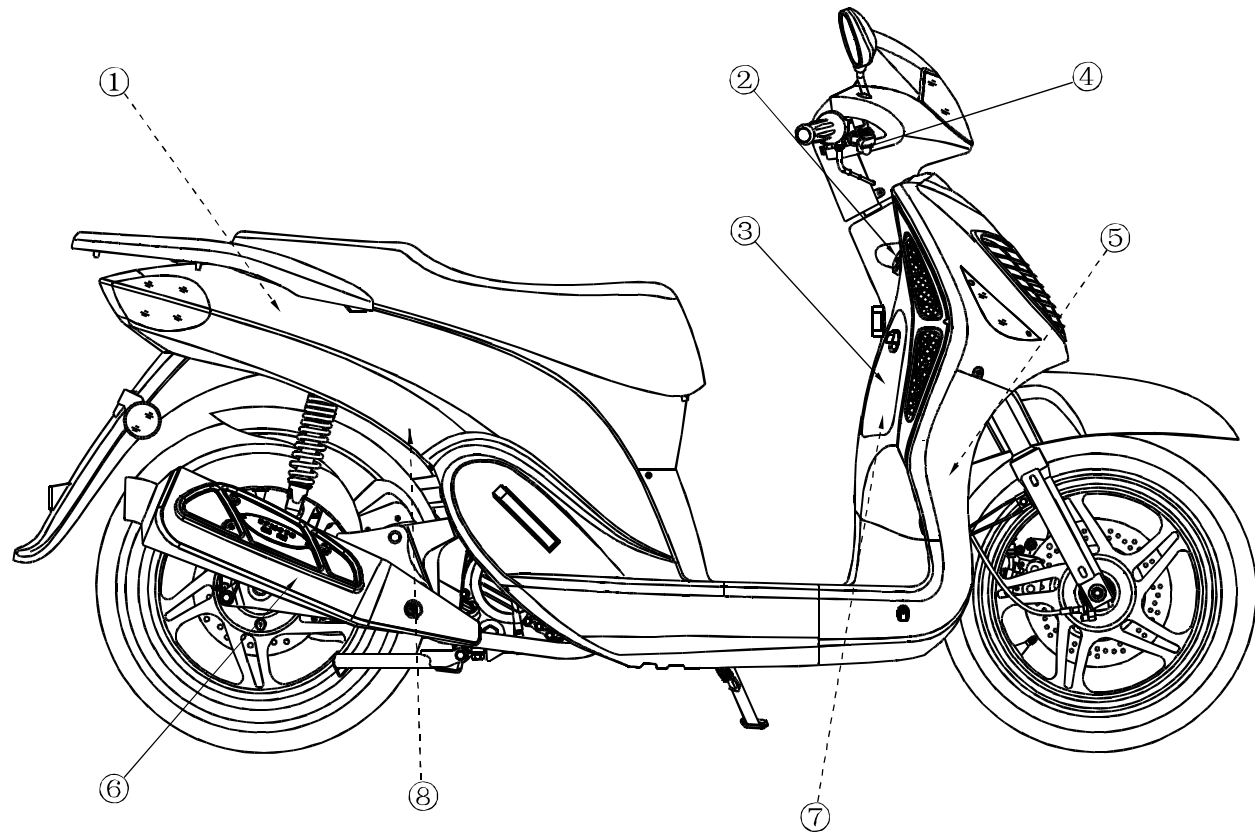

The position marked with ----- indicate the parts you may not see.

- ① Speedometer
- ② Odometer
- ③ Coolant temperature indicator
- ④ Fuel level indicator
- ⑤ Turn indicator (L)
- ⑥ Turn indicator (R)
- ⑦ High beam indicator
- ⑧ Parking indicator

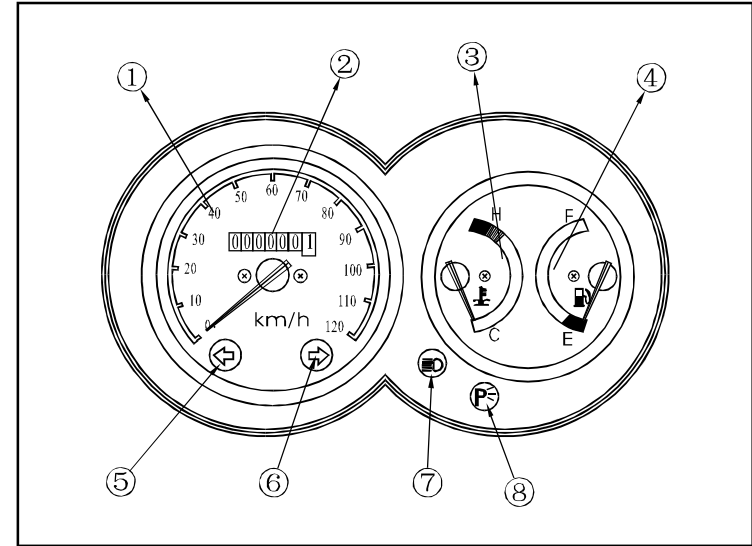



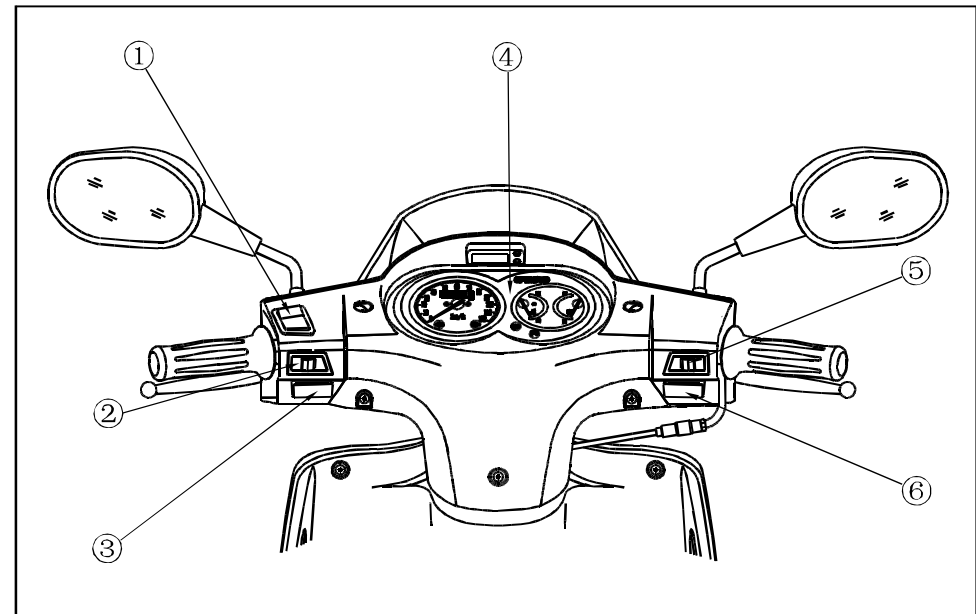



- ① Beam switch
- ② Turning switch (L&R)
- ③ Horn button
- ④ Instruments ASSY
- ⑤ Head light switch
- ⑥ Starting button



# OPERATION GUIDE

## MAIN SWITCH

Insert the key into the main switch lock

- 1):  when turning the switch to “”, the engine can be started and the key cannot be taken out.
- 2):  when turning the switch to “”, the engine will be stopped and the key can be taken out.
- 3):  turn the handlebar to the upmost left, press the key and turn to “” and then take out the key. The handlebar cannot be moved. The engine will not be started.

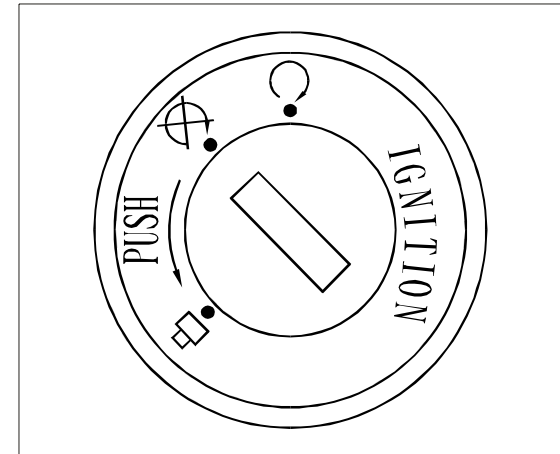
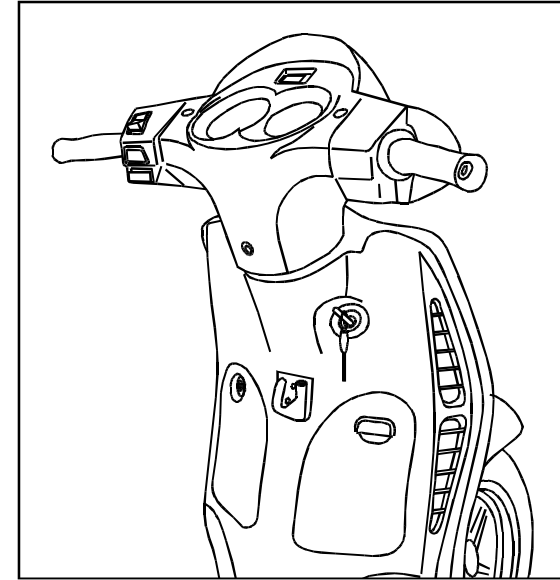

## TEMPERATURE INDICATOR

Temperature indicator is on the left of the instrument ASSY' right side which indicates the temperature of coolant. The white area of C indicates that the temperature is normal, while the red area of H indicates that the temperature is on the high side, in that case, please stop the engine and drive until the coolant temperature goes down. In case the temperature is repeatedly on higher side, check the coolant level when temperature is down (refer to Page 28), or check the cooling system at a professional maintenance station.

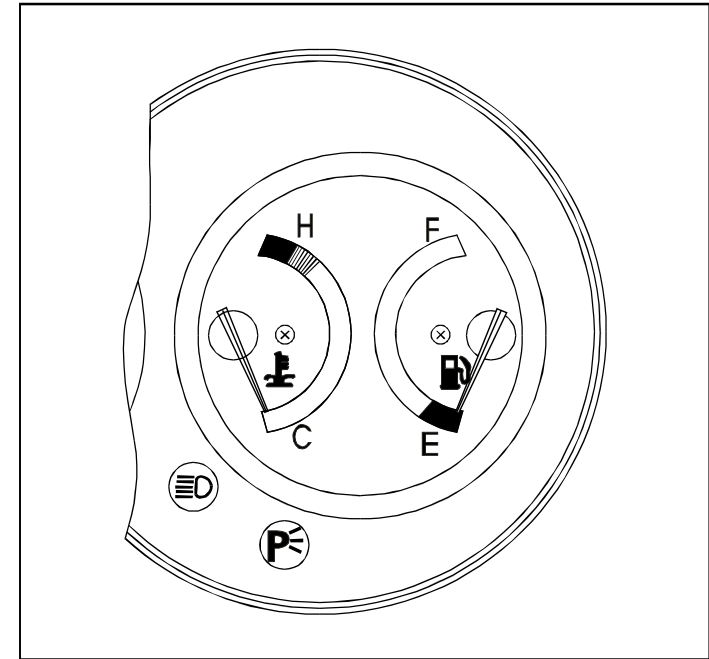

**NOTES:** If the engine runs idle in extremely hot weather for a long time the engine may be overheated, then stop the engine for cooling.

## FUEL LEVEL INDICATOR

Fuel level indicator is on the right of the instrument ASSY' right side which indicates the amount of the gasoline in the fuel tank. The red area of E indicates that the amount of the gasoline is only 1.0L, then please refill immediately.

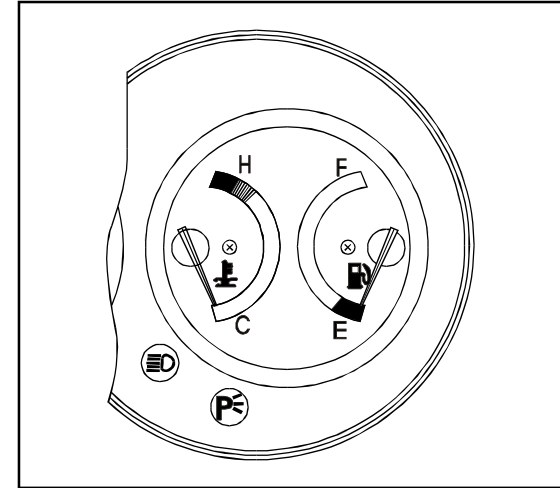

## BAGGAGE HOOK

Baggage hook ① is only for light loads, and its max. Load capacity is 1.5kg.

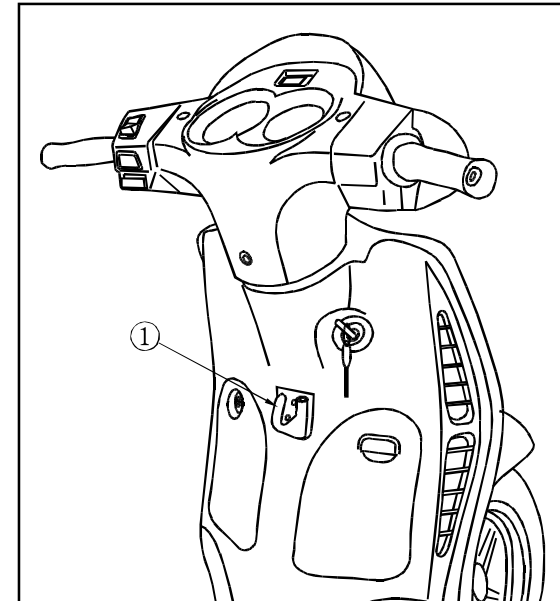

## HANDLEBAR SWITCH (L)

### ① Beam switch

The beam switch has two buttons, ☰○ and ☷○

Press ☰○ button for high beam;

Press ☷○ button for low beam.

### ② Turning light switch

Press the switch to ← for left turning ;

Press the switch to → for right turning .

### ③ Horn button

Press the button, and the horn will be on.

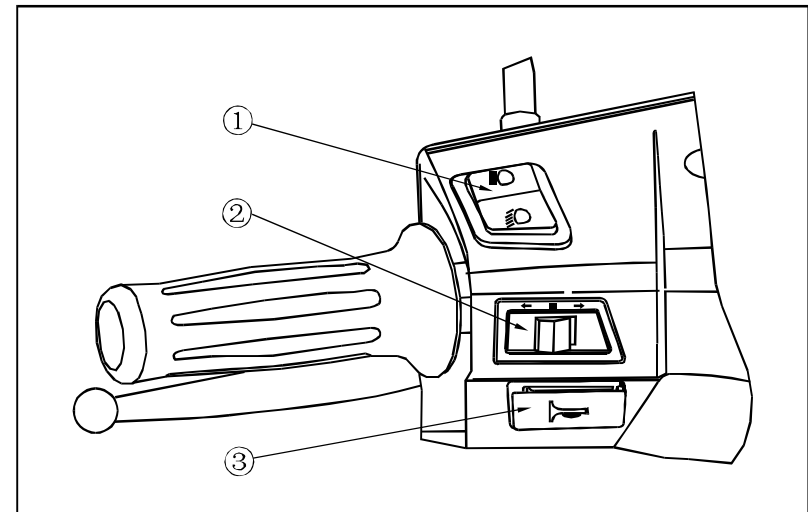

## HANDLEBAR SWITCH(R)

1. The illumination switch consists of three positions: ☼, ≡○≡ and ● ;

☼ : when the switch is at this position, headlight, the pilot light, taillight and instrument light are on;

≡○≡ : when the switch is at this position, taillight, the pilot light, and instrument light are on;

● : when the switch is at this position, headlight, taillight, the pilot light, and instrument light are off.

2. Electrical starting button

When pressing the button, engine will be started. For detailed procedures, please refer to Page 20.

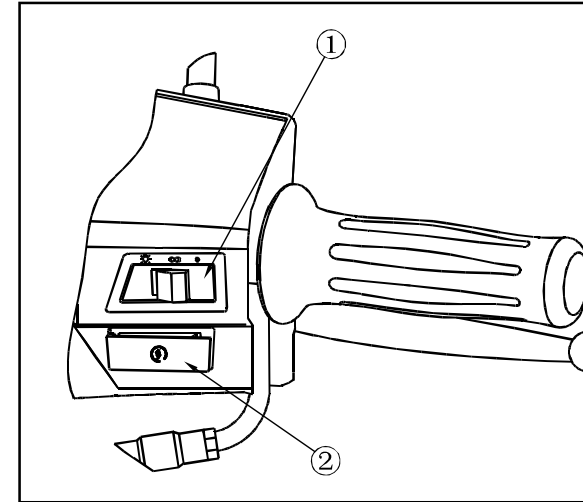

## SIDE STAND KILL SWITCH

The kill switch is installed beside the side stand.

When the side stand is at the position ①, the engine cannot be started.

When the side stand is at the position ②, the engine can be started.

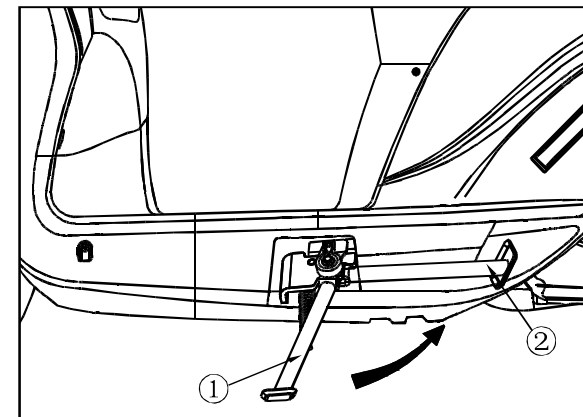

## FRONT TRUNK

Front trunk ① can only be used for light stuff.  
The Max. Load capacity is 1.0kg.

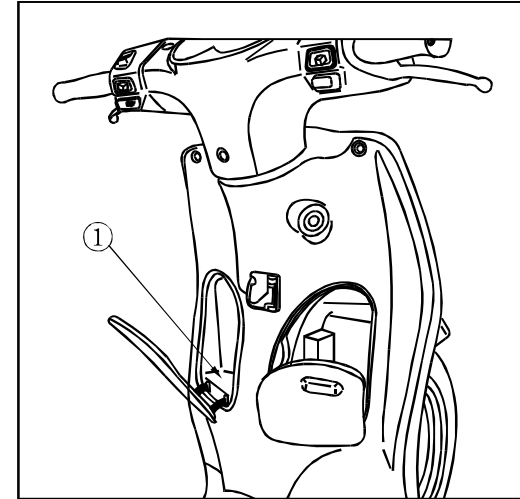

## STEERING LOCK

Turn the handlebar to the upmost left. Press the main switch key, and turn it to  , the handlebar will be locked.

Reverse above procedure for unlocking.

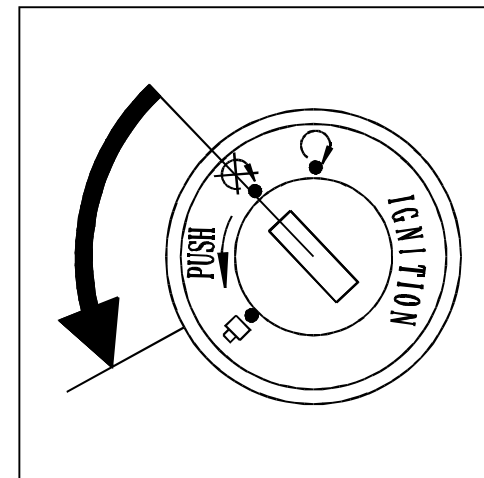



## SEAT LOCK

Insert the key into the lock at the left side of the seat and turn the key clockwise.

**CAUTION:** Lock the seat when driving.

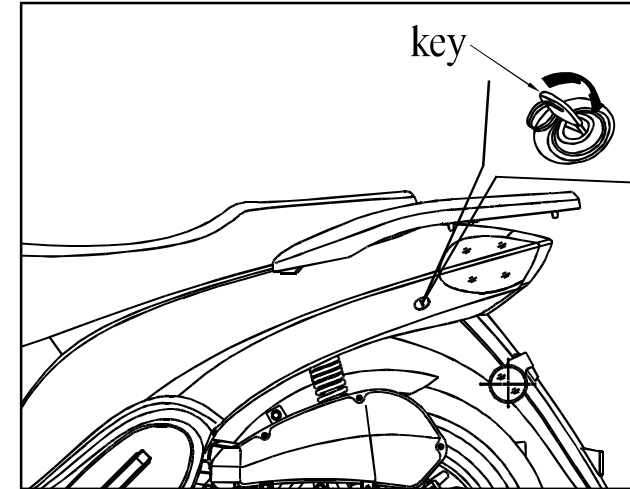

## TRUNK

Lift the seat and the trunk ① will be opened. Raincoat, tools, or books can be put in.

Max. Load capacity is 10.0 kg.

Close the seat, and the trunk will be locked.

## REAR BRAKE PARKING LEVER

Open the trunk, and turn the rear brake parking lever ② ON. When the circuit is ON, the “P” indicator on the instrument is OFF, and the engine can be started. Turn the rear brake parking lever ② OFF, and then the “P” indicator on the instrument is ON. The rear wheel is locked, and the engine cannot be started.

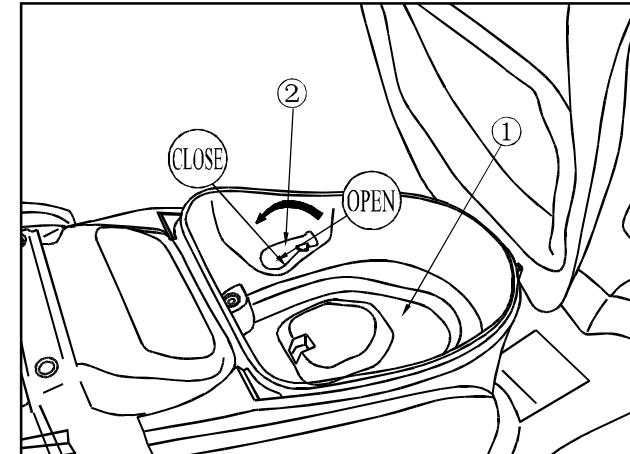

## INSPECTION BEFORE DRIVING

To ensure the performance and safety, a routine inspection shall be performed before drive.

### FUEL LEVEL

Once the fuel is insufficient, please refill in time. (Refer to fuel level indicator on Page 9).

Fuel tank capacity: 8.2L.

Turn the fuel tank cap ① counter clockwise, remove the cap , and then refill gasoline.

Turn the fuel tank cap ① clockwise, & tighten it.

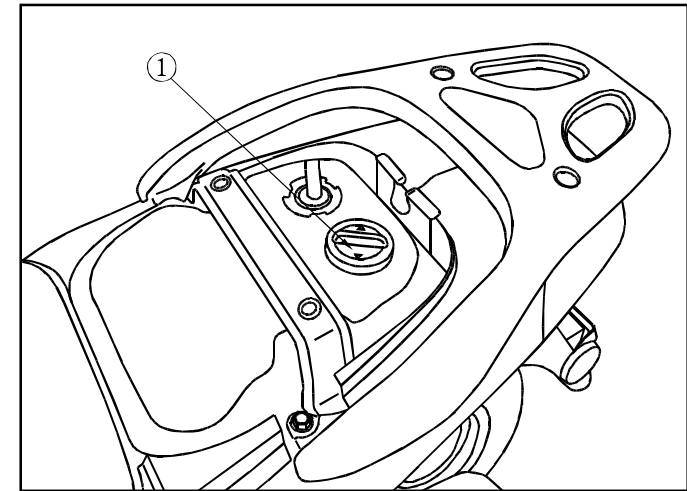

**CAUTION:** The fuel level shall be kept below the inlet fuel mark. Do not Mix gasoline and engine oil.

- Use fuel with octane number over 90.
- Be careful not to allow any dust, water or other pollutants into fuel tank when refilling.

## **WARNING :**

- Gasoline is flammable and it may explode under certain conditions, therefore refilling shall be made in a well-ventilated area after the engine has been stopped. No smoking or lighting of spark is permitted in gas station or fuel storage area.
- Do not over fill the tank. The amount of refilled fuel shall be kept below the fuel mark. Lock the cap after refilling.
- Gasoline is poisonous. Faint or death may occur if gasoline is swallowed. Do keep your skin away from gasoline. Do not breathe in the vapour of gasoline. Do keep it away from children. If gasoline is swallowed, induce vomit & consult the doctor.

## **CHECKING ENGINE OIL**

### **CHECKING ENGINE OIL LEVEL**

1. Park the scooter on a level surface and support it with its Main stand. remove oil dip rod ①, insert oil dip rod into the bottom of filler after wiping it clean with clean cloth, and then take it out .

2. If the oil level is near lower limit ②, fill with SAE15W-40/SF engine oil till the oil level is up to the upper limit③. Install oil dip rod and tighten it. Check for any leakage.

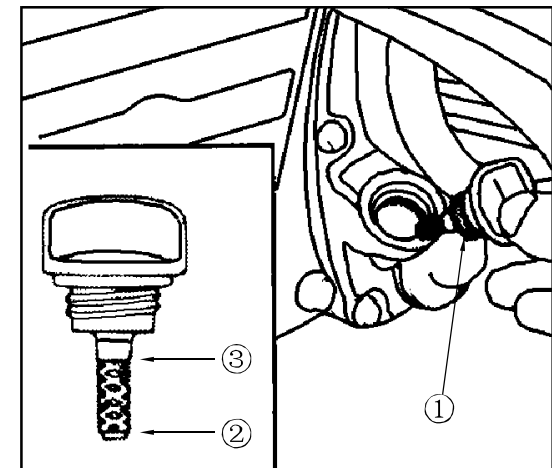

## BRAKE

### THE FREE TRAVEL OF THE BRAKE LEVER

Measure the moving distance of the top of the brake lever ① or ② between its natural position and functioning position.

This distance shall be 10 to 20 mm.

**NOTES:** The free travel of the brake lever should be 10 to 20 mm. If out of this range, please consult the local distributors or dealers.

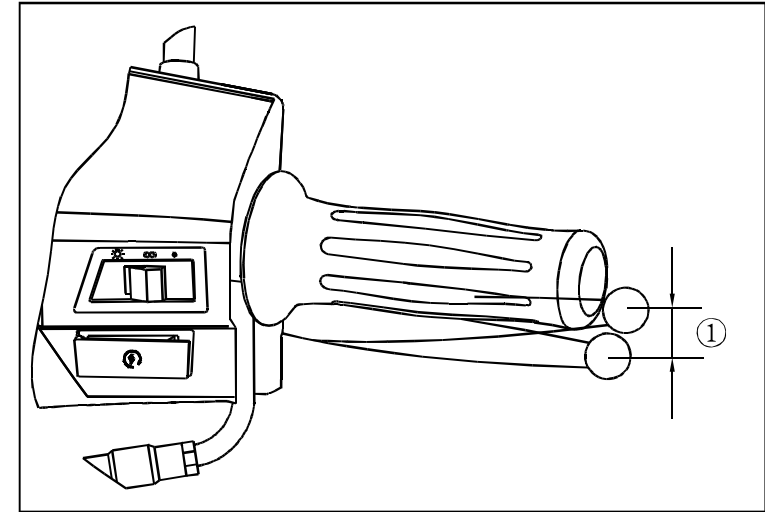

### WEARING OF FRONT BRAKE DISK

If the thickness of front brake disk is less than 3mm, the brake disk should be replaced.

### WEARING OF REAR BRAKE DISK

If the thickness of rear brake disk is less than 3mm, the brake disk should be replaced.

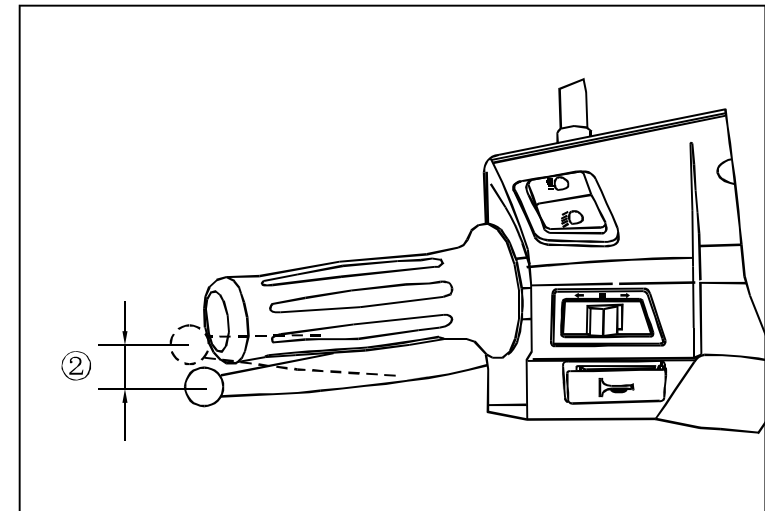

## TIRE

This scooter is assembled with tubeless tire. Only tires marked with “TUBELESS TIRE APPLICABLE” can be used. when installing the tire, the arrowhead direction on it should accord to the running direction of wheel. In addition the yellow point on tire should aim at valve.

Proper tire pressure will provide you maximum stability, comfort riding and longer tire life. Please check the tire pressure periodically and adjust it if necessary.

- NOTES:**
- Check the tire pressure while the tire is cool.
  - Tubeless tire has a certain self-sealing function. If the tire is punctured, it will leak slowly. Check the tire frequently if the tire is punctured especially when the tire cannot be inflated properly.

	150T-5A/125T-21A		150T-5/125T-21	
	Front tire	Rear tire	Front tire	Rear tire
Tire size	100/80-16	110/80-16	100/80-14	120/80-14
Tire pressure under cool condition (KPa)	250	250	225	225

Check for sliced mark on the tire surface or nail or other sharp objects on the tire and for any defects or damage of the rim. If there is any above case, please consult our local dealer for repairing or replacing and adjusting the balance of the wheels.

- WARNING:**
- Abnormal tire pressure will cause unstable driving and early damage of tire which may lead to accidents. And lower tire pressure will cause sliding or tire separation from rim.
  - It's dangerous to drive with excessively worn-out tire, and tough to drive due to the adherence between tire and road.

When the tread height of the tire reaches the mark “△” ① or the tread height is less than 1.6mm, the tire should be changed.

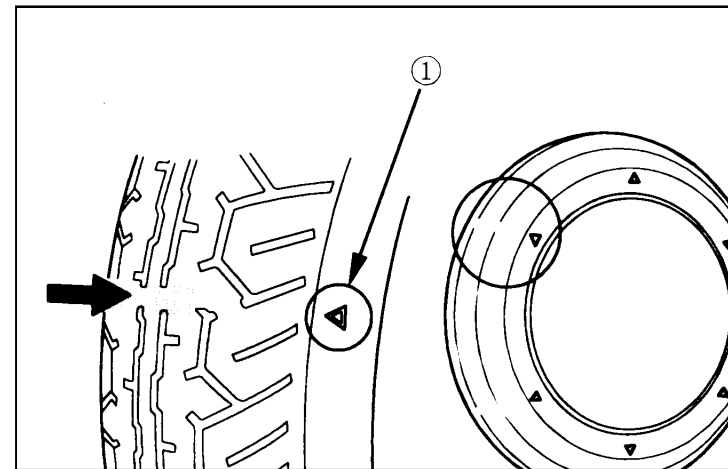

# STARTING THE ENGINE

Park the scooter with its main stand, draw in the side stand, open the seat lock, and turn the rear brake parking lever (Refer to Page 13).

- Insert the start key into the main switch and turn it to position ‘’ ;
- Hold the rear brake lever (Refer to Page 16), press starting button, and start the engine.

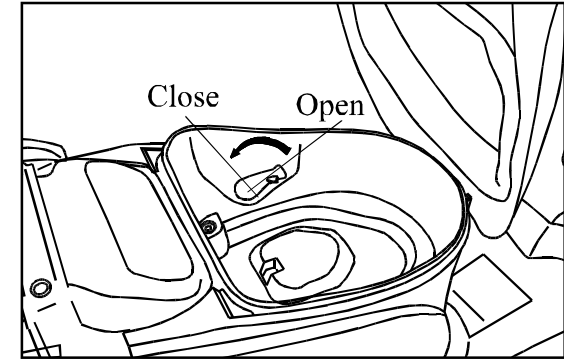

**WARNING:** ● Brake the rear wheel, otherwise it may run. Injury may happen if any person contacts the running wheel.

## NOTES :

- Release the starting button as soon as the engine is started.
- Do not press the starting button while the engine is running. Otherwise the engine may be damaged.
- Only when the rear wheel being braked, the engine can be started.
- The starting button must not be pressed For longer than 3 to 4 seconds. If the engine can not be started, release the starting button for 10 seconds. Restart The engine by slightly opening the throttle.

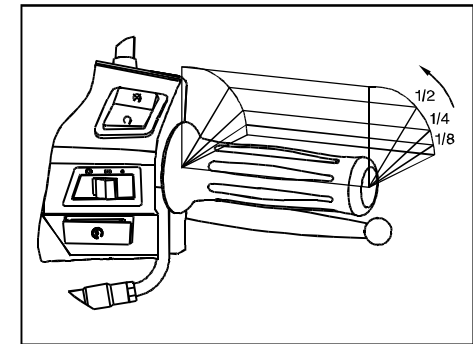
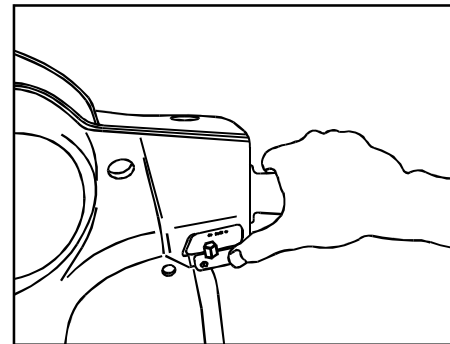
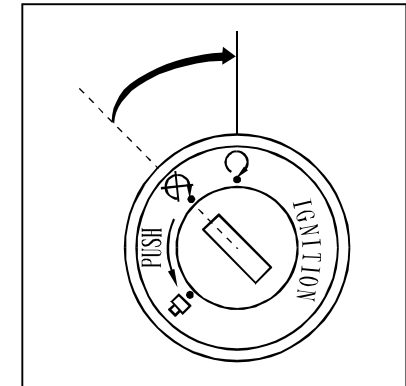

- If the scooter has been suspended from service for a long time or there is no fuel in the fuel tank, the starting time will be a little bit longer.

**NOTES:** Do not release the rear brake lever before the scooter starts to run.

## **DRIVING**

### **WARNING:**

- During the driving, the muffler is very hot. Contacting the muffler may cause serious burn. Therefore please wear trousers, avoid contracting the bare part of the muffler.
- Do not wear loose clothes, in case, the sleeves or trousers might get caught with pedals, wheel and tire.
- Any attachments installed on the scooter must be in accordance with the traffic laws and regulations of local governments.
- Any refitting or removal of the original parts will be dangerous and will not be allowed.

### **DRIVING PROCEDURE**

- (1) Push the scooter forward by the handlebars with the rear wheel being braked and the main stand returned.

**NOTE:** The engine may get damaged if it runs over the necessary time.

- (2) Sit on the seat with right foot on the footrest deck and left foot on the ground.



(3) Release the rear brake lever ( refer to Page 16 “ Brake ” )

**NOTE:** Do not release the rear brake lever before the scooter starts to run.

(4) Turn throttle slowly , and the scooter will start to run.

(5) Increase or release throttle for accelerating or slowing down.

### **WARNING:**

- Body injury may occur by contacting the running wheel. Do not make sudden acceleration to avoid losing control.

### **BRAKING THE SCOOTER**

(1) Release the throttle

Release the throttle to slow down scooter and engage the front and rear brakes simultaneously. This is very important.

**WARNING:** ● It will be difficult to control and stop the scooter when riding on wet or soft ground or in rain. Be careful when making a turn, accelerating or braking in the above mentioned conditions.

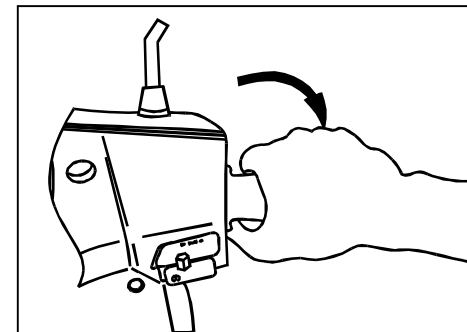
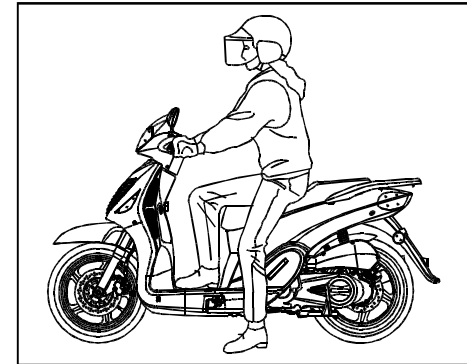
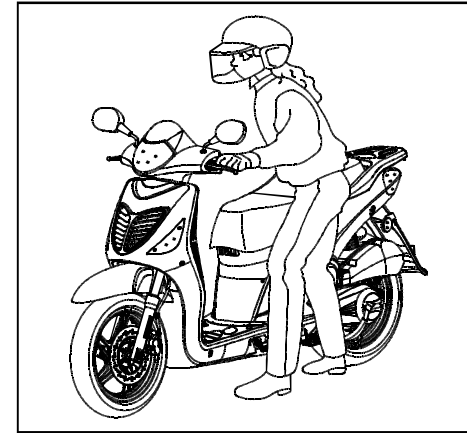

(2) Engage the front and rear brakes simultaneously

When driving down a steep slope , release the throttle and engage the front and rear brakes simultaneously. Do not brake continuously. Otherwise the brakes will be overheated which will result in lower braking efficiency.

**WARNING:** ● The front and rear brakes should be engaged simultaneously. The braking efficiency may be decreased if only one brake is applied. Engaging brake too frequently will block the wheel and decrease the performance of the scooter.

## PARKING

When you want to park the scooter, release the throttle, then engage the front and rear brakes simultaneously till the scooter is stopped. Turn the start key to ‘’, stop the engine.

Step on the main stand with right foot , lift the scooter by holding the rear bracket and park the scooter.

Lock the handle and pull out the start key (Refer to page12).

**WARNING:** ● Park the scooter on solid & level ground to avoid injury or damage to the scooter.

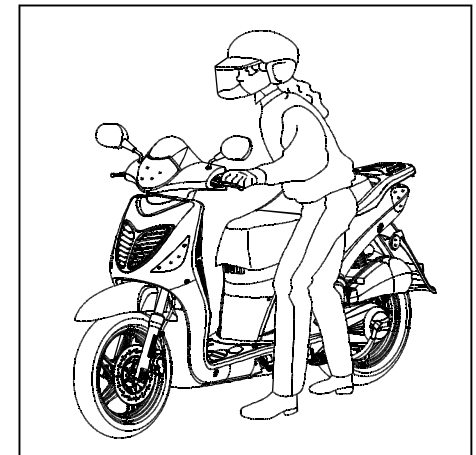
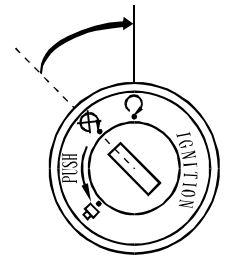

## **ANTI-THEFT**

- (1) Lock the handlebars and never leave the start key in the main switch.
- (2) Check the registration if it is correct or expired.
- (3) Leave the scooter in a garage if possible.
- (4) Use quality anti-burglar device.

## **MAINTENANCE INTERVAL**

The maintenance interval is based on the accumulated mileage and is the guideline for maintenance and lubrication of the scooter. The maintenance interval shall be shortened if the scooter always works in foul conditions at high speed. Please consult our local dealer for maintenance. If the scooter has been overhauled or collided, please consult technicians of the local dealer to check the main parts such as the frame, steering part & shock-absorbers.

If it is necessary to adjust the emission, consult a specialized centre.

**CAUTION:** To maintain the reliability and safety of the scooter, never refit the scooter.

**WARNING:** ● To avoid injury, maintenance shall be performed after the engine has been stopped and the scooter has been properly parked.

**CAUTION:** If the scooter shall be suspended from service for more than one month or in winter, maintenance shall be carried out to prevent the fuel, the tire, and the battery from deteriorated or eroded.

## MAINTENANCE INTERVAL TABLE

Perform the instructions in the Inspection Before Driving section (refer to Page 14) prior to each periodical maintenance.

I: Inspecting , cheaning , adjusting , lubricating or replacing when necessary.

C: Cleaning R: Replacing

A: Adjusting L: Lubricating

### NOTE:

\* Consult the local dealer for maintenance & repairing unless the driver or the owner has the full set of special tools or is a qualified technician.

\*\* We recommend that the maintenance of the items be done by the technicians of the local dealers.

[1]: If the odometer readings is reached high, perform the periodical maintenance.

[2]: If environment is humid or dusty the maintenance interval shall be shortened.

[3]: If riding frequently on bumpy road, maintenance must be performed.

[4]: Replacing should be done by experienced technicians every two years.

Item		Interval		Odometer Readings(kms)/month[1]				
		1000	4000/6	8000/12	12000/18	Refer to Page		
*	Fuel pipe		I	I	I			
*	Throttle		I	I	I			
	Air cleaner[2]	R	R	R	R		26	
	Spark plug		I	R	I		31	
*	Valve clearance	I	I	I	I			
	Engine oil	R	R for Every 3000km				28	
*	Oil screen				C			
*	Carburetor Idle speed	I	I	I	I			
	Coolant[4]			I				
*	Cooling system			I				
	Driving belt	I	R for every 16000kms					
	Small air cleaner		C	C	C		26	
*	Gearbox lubrication oil[4]						30	
	Brake shoe (Disk)		I	I	I			
	Brake system	I	I	I	I			
	Brak light switch		I	I	I			
*	Brake lock	I	I	I	I			
*	Illumination lights		I	I	I			
**	Clutch shoe			I				
	Central, side stands		I	I	I			
*	Suspension		I	I	I			
*	Bolts,nuts,fasteners[3]	I		I				
**	Wheel and tire		I	I	I			
**	Steering fork bearing	I			I			
*	Battery	I of every 3000km						

## MAINTENANCE

### AIR CLEANER

- (1) Remove 5 screws ① of the air cleaner.
- (2) Remove the cover ②.
- (3) Remove the filter element ③.
- (4) Clean the dust on the filter element with brush or air bump.  
Replace if the element is hard to be cleaned.
- (5) Install the air cleaner.

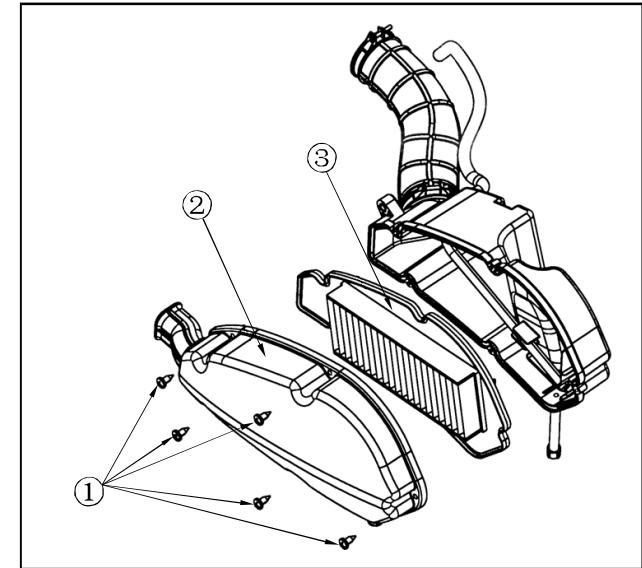

### SMALL AIR CLEANER

- (1) Remove the screw ① and the small air cleaner cap ⑤ ;
- (2) Remove the filter element ④ , and fender ③ ;
- (3) Clean the filter element with nonflammable or high flare point solution, then dry it naturally;
- (4) Clean the inner sides of the small air cleaner cap ⑤, the small air cleaner body ② , and the fender ③, then install the small air cleaner.

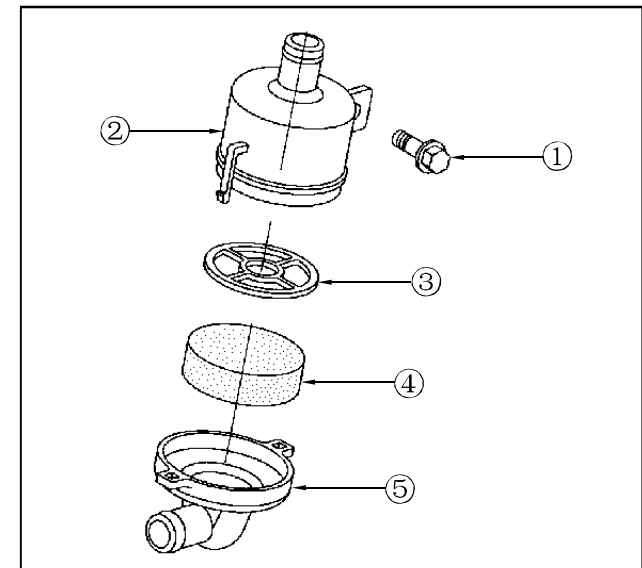

## LEFT SIDE COVER INLET VENTILATOR

The engine left side cover inlet ventilator is on the top of left side cover.

- (1) Remove the screw ① and the inlet ventilator cover ②;
- (2) Take out the filter element ③;
- (3) Clean the filter element with water, and then dry it. Replace if necessary.
- (4) Install the filter element ③ and inlet ventilator cover ②.

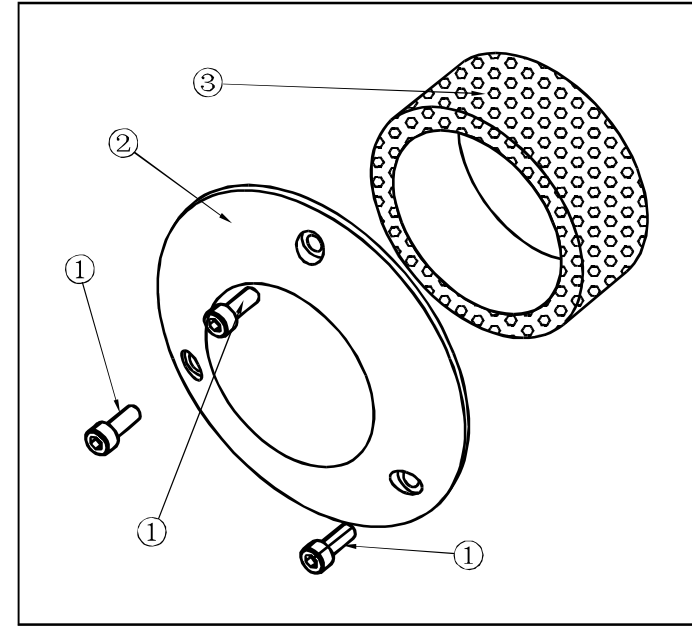

**WARNING:** ● Never clean the filter element with gasoline or low flare point solution.

**CAUTION:** Do not apply lubricant or grease to the element to avoid damage to engine parts.

## RADIATOR

### RADIATOR

The radiator is located on the lower part of front top cover. A periodical maintenance should be performed to clean the dust and deposit, according to the road conditions.

### RECOMMENDED COOLANT

You can only use the high quality glycol coolant with erosion inhibitor for aluminum engines. The scooter has been filled with coolant containing 50% anti-freezer and 50% water. If coolant replacement is necessary, the adding capacity of coolant should be about 800ml.

### CHECK COOLANT CAPACITY

- Coolant level ① .
- If the coolant level is at the LOWER mark ② , open the right cover of front trunk ④ , and then open the cap of the coolant tank to add coolant until the coolant level is up to the UPPER mark ③ .
- The capacity of the secondary water tank 260ml.

### ENGINE OIL

High quality engine oil is of ideal performance . Only high quality scooter engine oil SE or SF Grade with high de-pollution performance can be used. No additives is needed.

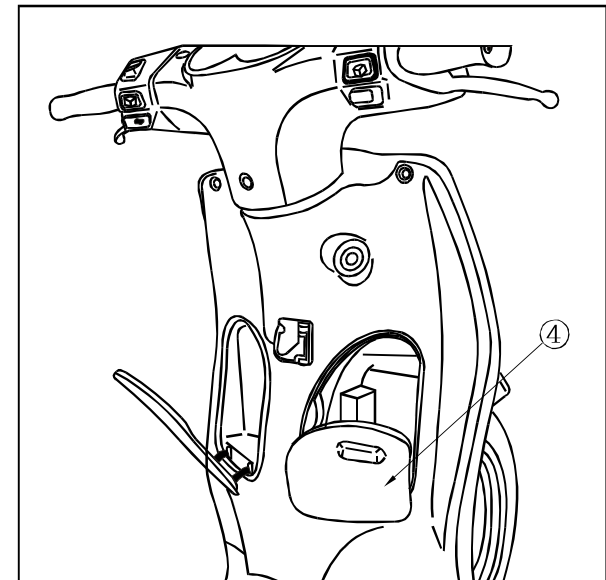
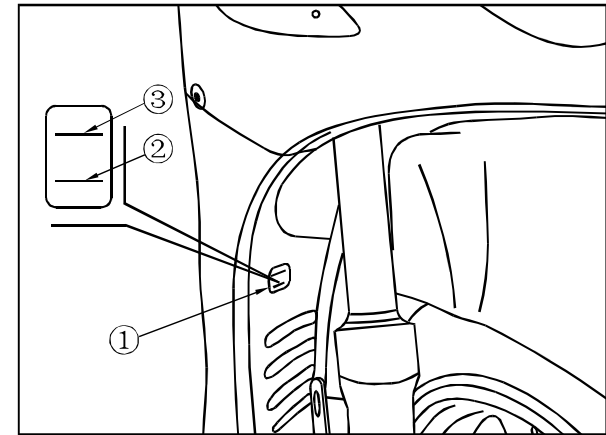



## Recommended engine oil

SE Grade	SAE10W-30
SF Grade	SAE15W-40 SAE20W-50

## VISCOSITY:

The viscosity of the engine oil shall be in accordance with the local climate condition. The figure on the right provides a guideline for selecting the engine oil viscosity for different atmospheric temperature.

**NOTE:** CHUNFENG special engine oil recommended.

## REPLACING ENGINE OIL AND CLEANING OIL SCREEN

### CRANKCASE CAPACITY

First filling: 1.0L periodical changing: 0.8L

### REPLACING OIL

- Replacing Interval: first time at 1000kms, then at each 3000kms;
- Park the scooter with main stand, and replace oil when the engine is still warm for complete drainage of the used oil.

(1) Remove the oil dip rod, and oil screen cover ①, and then remove drain bolt.

**NOTE:** With the screen cover being removed, the oil screen ③ and the spring ② can be taken out.

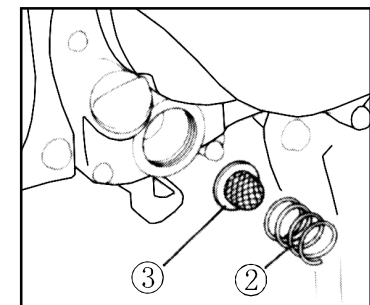
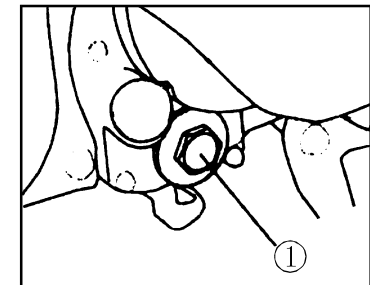
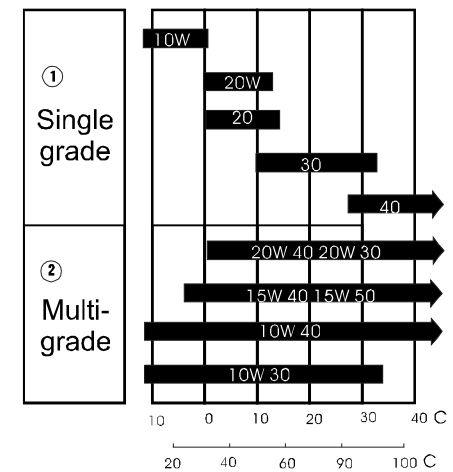

- (2) Clean the oil screen with solution ;
- (3) Install oil screen、 spring , oil screen cover & drain bolt ;
- (4) Fill the crankcase with qualified engine oil till it reaches the UPPER mark; When checking oil level, screw in the oil dip rod ;
- (5) Install the oil dip rod ;
- (6) Start the engine and run it idle for a few minutes . Then stop the engine.
- (7) The engine oil lever should be above the middle line of the LOWER and UPPER mark.

## REPLACING GEARBOX OIL

Recommended gearbox oil type: SAE15W – 40

- (1) Park the scooter with the main stand ;
- (2) Remove the filling bolt ① and the drain bolt ② ;
- (3) Clean the drain bolt and install it ;
- (4) Fill gear oil through the filling hole till it overflows ;
- (5) Install the filling bolt.

**NOTE:** Park the scooter with main stand and drain the oil while the engine is still warm to ensure fast & clean drainage.

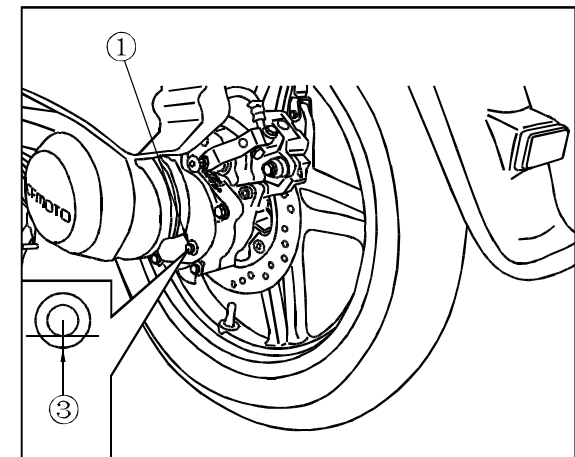
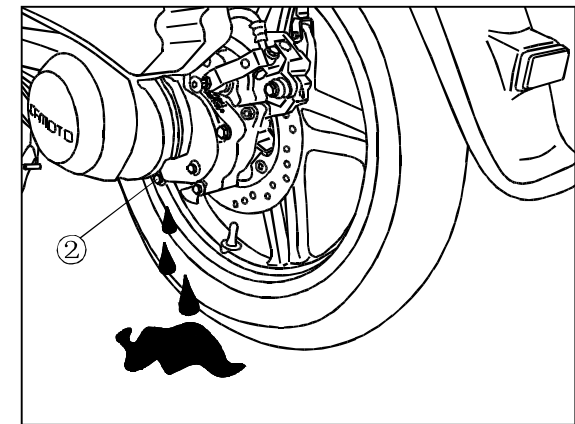

## SPARK PLUG

Type of the spark plug: DPR7EA-9(NGK)/D7RTC(TORCH)

- (1) Remove cap, and remove spark plug with spark plug wrench;
- (2) Check the electrode and the central ceramic point for carbon deposit, or wearing. If necessary, replace the spark plug. Clean off the deposit with spark plug cleaning detergent or brush.
- (3) Measure the spark plug gap ① with a feeler gauge. Bend the side electrode ② & adjust the gap ① to 0.8mm~0.9mm. The gap should not be too small.

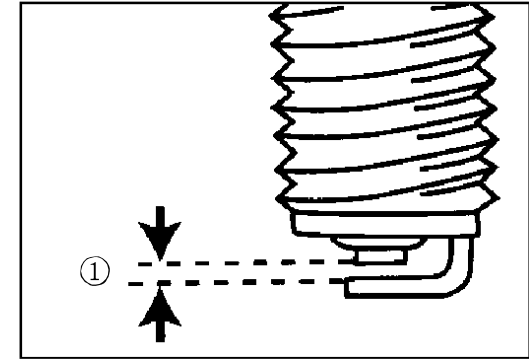

## BATTERY

Battery type: 12V 7 Ah.

Remove rubber floor mat, remove the screw ①, then open the cover ②. Remove the battery tightening plate, and the +/- screws. Take out the battery.

**CAUTION:** When replacing battery, connect the red wire with + electrode & the Black wire to - electrode, Or you may damage the cable & Battery.

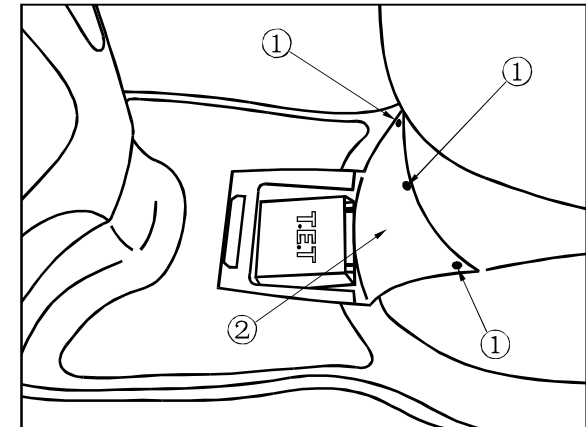

## REPLACING THE FUSE

The main fuse is located above the starter relay under the seat. Rated current: 20A. Remove the line connector, and you will see it.

The fuse box① is in the front right trunk. Rated current: 10A & 5A

If the fuse is frequently burnt , it indicates short circuit or overload in the electrical system; you should consult the local dealer.

**CAUTION:** Turn the main switch to ‘  ’ when checking or replacing fuse to avoid short circuit.

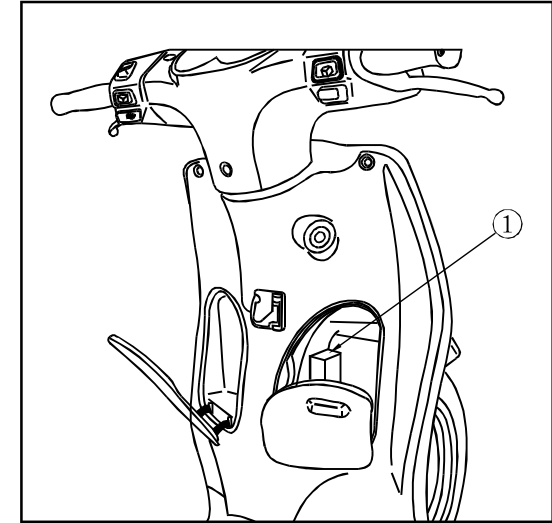

Replacing: Remove the used fuse and install a new one.

**WARNING:** ● Only use the fuse of specified current capacity. Using incorrect fuse may result in damage to the electrical system, or causing fire. Incorrect fuse may also cause illumination failure or engine failure during night driving.

## **TOOLS**

The tool kit is in the compartment below the seat. These tools are enough for minor repairing、 adjusting or part replacing . The tool kit includes :

- 8 × 10mm open end wrench
- 12 × 14mm open end wrench
- 13 × 16mm open end wrench
- S=6 Internal hex wrench
- double-end screw driver
- screw driver handle
- 16 × 18mm socket wrench
- cross screw driver for adjusting idle speed
- tool kit

# SERIAL NUMBER

The serial number of the frame and the engine are used for registration, applying driving license and ordering parts.

The frame No.(VIN) ① is located in the front of battery box. Remove the cover, and you will see it. The label ② is located in the right beam of the front of engine. The engine No.③ is located on the back of the engine.

Frame No. \_\_\_\_\_

Engine No. \_\_\_\_\_

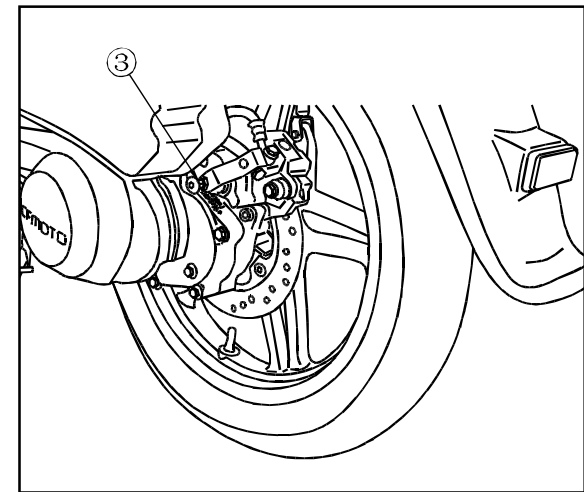
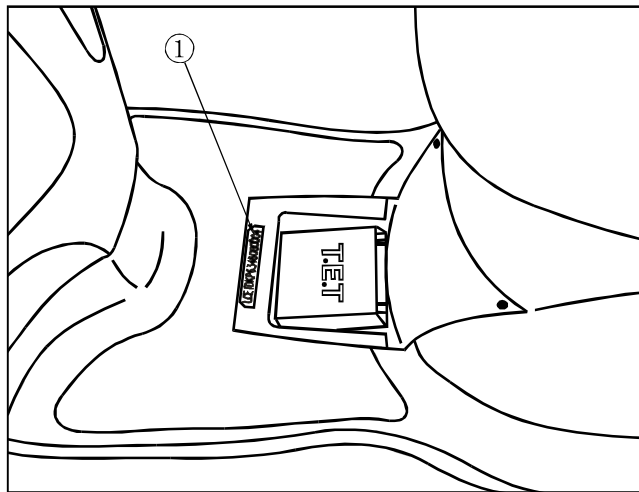
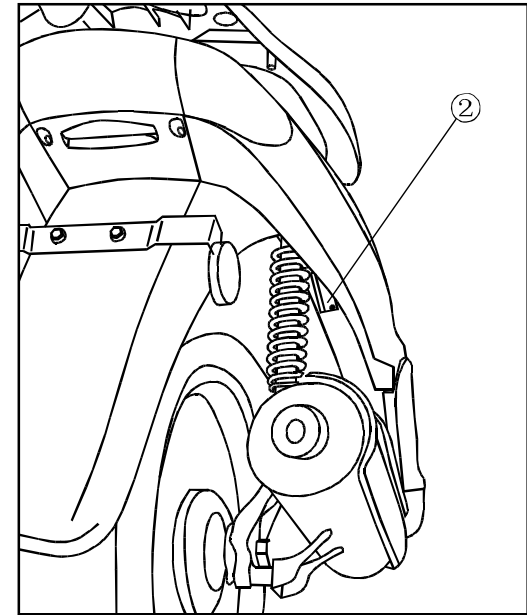

## GUIDELINE FOR STORAGE

### STORAGE

If the scooter will be stored for a long period of time, such as in winter, necessary measures shall be taken to prevent damage or malfunction of parts . In addition , some repairing is necessary .

(1) Replace the engine oil and the oil screen ;

(2) Drain the fuel tank and carburetor completely. Spray the inner surface of the fuel tank with anti-rust oil, then lock the fuel tank cap .

**WARNING:** ● Gasoline is flammable or explosive. Do not smoke or use fire when draining fuel.

(3) Remove the spark plug, fill the cylinder with 15 to 20 mL engine oil. Crank the engine for several times to spread the oil over the cylinder . Install the spark plug .

**CAUTION:** When cranking the engine, be sure to ground the spark plug with cap on.

(4) Remove the battery, and store the battery in a place with no icing or direct sunlight. Charge the battery once a month .

(5) Clean all surfaces of the scooter and wipe dry. All the painted surfaces shall be coated with wax and then with anti-rust oil.

(6) Inflate the tires to the standard pressure. Park the scooter & support the tires with wooden blocks.

(7) Cover the scooter with a cover made of non-plastic or non-glue-coated cloth, and place it in a dry, shady and cool environment without direct sunlight.

## **REUSE OF THE SCOOTER**

(1) Remove the scooter cover and wipe it clean. If the scooter has been stored for more than 4 months, replace the engine oil.

(2) Check the electrolyte's level. Charge the battery, if necessary.

(3) Clean off the anti-rust oil in of the fuel tank. And fill gasoline.

(4) Perform the procedures specified in Inspection Before Driving ( page 14 ) and drive the scooter at lower in areas with less traffic.



## TECHNICAL PARAMETER

<b>TYPE</b>	150T-5/ 125T-21	150T-5A/ 125T-21A
<b>DIMENSIONS</b>		
Length	2030mm	2075mm
Height	690mm	690mm
Width	1155mm	1200mm
Wheel base	1365mm	1385mm
Ground clearance	125mm	160mm
<b>WEIGHT</b>		
Net weight	127kg	130kg
<b>CAPACITY</b>		
Crankcase/Gearbox	1.0L / 0.18L	
Fuel tank	8.2L	
Max. Load	150kg	
<b>ENGINE</b>		
Type	Single cylinder, horizontal, water cooled, 4 stroke	

<b>TYPE</b>	150T-5/ 125T-21	150T-5A/ 125T-21A
Bore × stroke (mm × mm)	58 × 57.8/ 52.4 × 57.8	58 × 57.8/ 52.4 × 57.8
Compression ratio	10.3 : 1	10.3 : 1
Displacement (ml)	152.7/124.6	152.7/124.6
<b>SPARK PLUG</b>		
Type	DPR7EA-9(NGK) / D7RTC(TORCH)	
Gap	0.8~0.9mm	
Idle speed	1600 ± 160r/min	
<b>TIRE</b>		
Front	100/80-14	100/80-16
Rear	120/80-14	110/80-16
<b>MAIN PERFORMANCE DATA</b>		
Rated power (kw/r/min)	6.5/7000 /6.0/7000	6.5/7000 /6.0/7000
Max. Speed	≥85km/h	
Fuel consumption	≤2.5L/100km	

<b>TYPE</b>	150T-5/ 125T-21	150T-5A/ 125T-21A
<b>TRANSMISSION</b>		
Reduction Ratio	10.07/12.10	10.07/12.10
<b>ELECTRICAL SYSTEM</b>		
Battery	12V、 7Ah	
Alternator	AC Magneto	
<b>LIGHT</b>		
Headlight	Headlight bulb 12V 35W/35W pilot light 12V, 3W	
Brake/Tail light	12V 21W/5W	
Fuse	20A/10A/5A	
Front turn light	12V 10W×2	
Rear turn light	12V 10W×2	
<b>PILOT LIGHT</b>		
Turning signal indicator	12V 3.4W×2	
High beam indicator	12V 3.4W	
Panel lamp	12V 1.7W×3	

# ELECTRICAL DIAGRAM

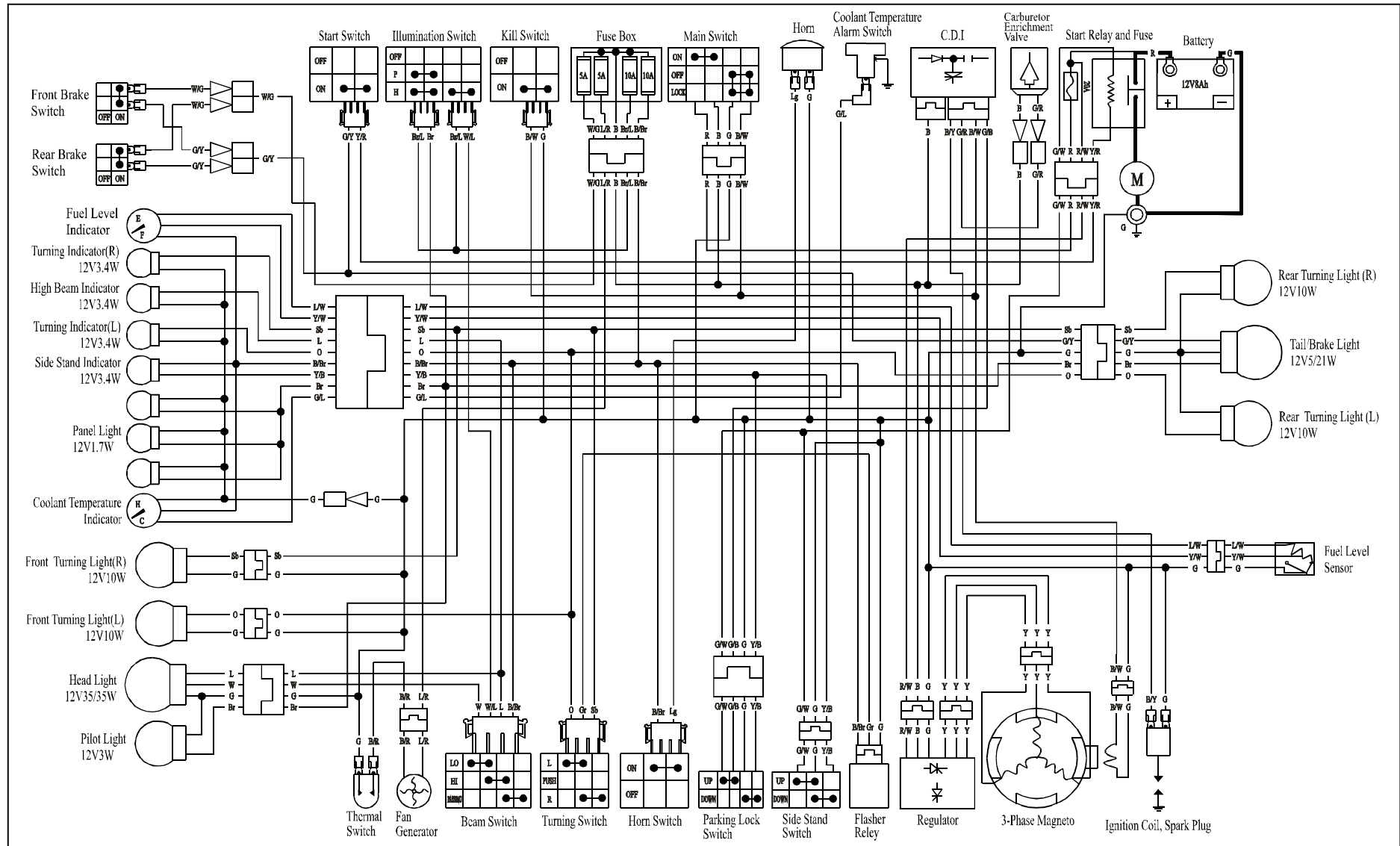

R-Red B-Black G-Green L/R-Blue/Red G/Y-Green/Yellow Y/R-Yellow/Red Br-Brown Y-Yellow L-Blue W-White O-Orange B/Br-Black/Brown  
 Br/L-Brown/Blue W/G-White/Green B/W-Black/White B/Y-Black/Yellow Y/W-Yellow/White Lg-Light Green Gr-Grey G/L-Green/Blue  
 G/R-Green/Red Sb-Sky Blue W/L-White/Blue R/W-Red/White B/R-Black/Red G/B-Green/Black L/W-Blue/White

